Quick Start Guide

Agilent 86130A BitAlyzer[®] Error Performance Analyzer



Agilent Technologies

© Copyright 2001, 2002
Agilent Technologies
All Rights Reserved. Reproduction, adaptation, or translation without prior written permission is prohibited, except as allowed under copyright laws.

Agilent Part No. 86130-90050
Printed in USA
May 2002

Agilent Technologies
Lightwave Division
3910 Brickway Boulevard
Santa Rosa, Ca. 95403, USA

Notice.

The information contained in this document is subject to change without notice. Companies, names, and data used in examples herein are fictitious unless otherwise noted. Agilent Technologies makes no warranty of any kind with regard to this material, including but not limited to, the implied warranties of merchantability and fitness for a particular purpose. Agilent Technologies shall not be liable for errors contained herein or for incidental or consequential damages in connection with the furnishing, performance, or use of this material.

Restricted Rights Legend.

Use, duplication, or disclosure by the U.S. Government is subject to restrictions as set forth in subparagraph (c) (1) (ii) of the Rights in Technical Data and Computer Software clause at DFARS 252.227-7013 for DOD agencies, and subparagraphs (c) (1) and (c) (2) of the Commercial Computer Software Restricted Rights clause at FAR 52.227-19 for other agencies.

Warranty.

This Agilent Technologies instrument product is warranted against defects in material and workmanship for a period of one year from date of shipment. Dur-

ing the warranty period, Agilent Technologies will, at its option, either repair or replace products which prove to be defective. For warranty service or repair, this product must be returned to a service facility designated by Agilent Technologies. Buyer shall prepay shipping charges to Agilent Technologies and Agilent Technologies shall pay shipping charges to return the product to Buyer. However, Buyer shall pay all shipping charges, duties, and taxes for products returned to Agilent Technologies from another country.

Agilent Technologies warrants that its software and firmware designated by Agilent Technologies for use with an instrument will execute its programming instructions when properly installed on that instrument. Agilent Technologies does not warrant that the operation of the instrument, or software, or firmware will be uninterrupted or error-free.

Limitation of Warranty.

The foregoing warranty shall not apply to defects resulting from improper or inadequate maintenance by Buyer, Buyer-supplied software or interfacing, unauthorized modification or misuse, operation outside of the environmental specifications for the product, or improper site preparation or maintenance.

No other warranty is expressed or implied. Agilent Technologies specifically disclaims the implied warranties of merchantability and fitness for a particular purpose.

Exclusive Remedies.

The remedies provided herein are buyer's sole and exclusive remedies. Agilent Technologies shall not be liable for any direct, indirect, special, incidental, or

consequential damages, whether based on contract, tort, or any other legal theory.

Safety Symbols.

CAUTION

Caution denotes a hazard. It calls attention to a procedure that, if not correctly performed or adhered to, could result in damage to or destruction of the product. Do not proceed beyond a caution note until the indicated conditions are fully understood and met.

WARNING

Warning denotes a hazard. It calls attention to a procedure which, if not correctly performed or adhered to, could result in injury or loss of life. Do not proceed beyond a warning sign until the indicated conditions are fully understood and met.



The instruction documentation symbol. The product is marked with this warning symbol when it is necessary for the user to refer to the instruction in the documentation.



The AC symbol is used to indicate the required nature of the line module input power.



The ON symbols are used to mark the positions of the instrument power line switch.



The Standby symbol is used to mark the position of the instrument power line switch.



The OFF symbols are used to mark the positions of the instrument power line switch.



The CE mark is a registered trademark of the European Community.



The CSA mark is a registered trademark of the Canadian Standards Association.

ISM1-A This is a symbol of an Industrial Scientific and Medical Group 1 Class A product..

Typographical Conventions.

The following conventions are used in this book:

key type for keys or text located on the keyboard or instrument.

softkey type for key names that are displayed on the instrument's screen.

display type for words or characters displayed on the computer's screen or instrument's display.

user type for words or characters that you type or enter.

emphasis type for words or characters that emphasize some point or that are used as place holders for text that you type.

In This Book

This book gives you the information you need to begin using the Agilent 86130A BitAnalyzer. It contains five chapters:

[Chapter 1, “Setting Up the 86130A”](#) contains inspection, power requirements, air flow, and setup information.

[Chapter 2, “Working in Comfort”](#) contains recommendations for working comfortably and safely while operating the Agilent 86130A.

[Chapter 3, “Using the Agilent 86130A”](#) gives an overview of the front panel and the graphical user interface.

[Chapter 4, “Using the Built-In Information System”](#) describes the built-in information system contents and navigation. The built-in information system contains all of the information that is generally found in a user’s guide.

[Chapter 5, “Regulatory Information”](#) contains important regulatory information.

- For detailed information on how the Agilent 86130A makes measurements and how to use the instrument, see the built-in information system in the instrument.
- For information on programming the Agilent 86130A using a computer with a GPIB interface card, refer to the *Agilent 86130A BitAnalyzer Error Performance Analyzer Programmer’s Guide*.

CAUTION

The Agilent 86130A uses a specially designed Windows NT application program (Windows® is a U.S. registered trademark of Microsoft Corp.) All Agilent 86130A functionality is directly available from within the Agilent 86130A application. Windows NT configuration changes made outside of the Agilent 86130A application may not work correctly and could cause the instrument to become inoperable. Do not try to access or make changes to the Windows Operating system. Repairs caused by the improper use of the Agilent 86130A will not be covered under warranty.

General Safety Considerations

This product has been designed and tested in accordance with the standards listed on the Manufacturer's Declaration of Conformity, and has been supplied in a safe condition. The documentation contains information and warnings that must be followed by the user to ensure safe operation and to maintain the product in a safe condition.

Install the instrument according to the enclosure protection provided. This instrument does not protect against the ingress of water. This instrument protects against finger access to hazardous parts within the enclosure.

WARNING

If this product is not used as specified, the protection provided by the equipment could be impaired. This product must be used in a normal condition (in which all means for protection are intact) only.

WARNING

No operator serviceable parts inside. Refer servicing to qualified personnel. To prevent electrical shock, do not remove covers.

WARNING

For continued protection against fire hazard, replace line fuse only with same type and ratings (type 5A/250V, p/n 2110-0709). The use of other fuses or material is prohibited.

WARNING

To prevent electrical shock, disconnect the Agilent Technologies model 86130A from mains before cleaning. Use a dry cloth or one slightly dampened with water to clean the external case parts. Do not attempt to clean internally.

CAUTION

Do not use too much liquid in cleaning the instrument. Water can enter the front-panel keyboard, damaging sensitive electronic components.

In This Book iii
General Safety Considerations iv

1 Setting Up the 86130A

Installing the 86130A 1-3
Cleaning Connections for Accurate Measurements 1-26
Returning the Instrument for Service 1-30
Agilent Technologies Service Offices 1-33

2 Working in Comfort

About Repetitive Strain Injury 2-3
Mice and Other Input Devices 2-5

3 Using the Agilent 86130A

Front and Rear Panel 3-4
Menus 3-7
On-Screen Keyboard 3-10

4 Using the Built-In Information System

The Contents of the Built-In Information System 4-3
Learning How to Set Up the 86130A and Make BER Measurements 4-6
Getting Help From the Main Window or Dialog Box 4-7
Hiding the Built-in Information System 4-10
Printing the Contents of a Topic 4-11
Selecting the Built-in Information System Language 4-12

5 Regulatory Information

Compliance with German Noise Requirements 5-3
Compliance with Canadian EMC Requirements 5-4

Contents

Setting Up the Agilent 86130A	1-2
Step 1. Inspect the shipment	1-4
Step 2. Connect the keyboard and mouse	1-7
Step 3. Connect the line cord	1-8
Step 4. Turn on the line power	1-12
Step 5. Set the time and date	1-13
Step 6. Connect a printer	1-15
Step 7. Configure the touch screen	1-18
Step 8. Avoid costly repairs	1-21
Step 9. Perform a quick confidence check	1-22
Step 10. Configure for Bench Top or Rack Mount Use	1-24
Step 11. For more information	1-25
Cleaning Connections for Accurate Measurements	1-26
Returning the Instrument for Service	1-30
Agilent Technologies Service Offices	1-33

Setting Up the 86130A

Setting Up the Agilent 86130A

This chapter shows you how to set up your 86130A and connect the power and the accessories. It also shows you how to use proper optical connection cleaning techniques to avoid *costly* repairs.

WARNING

This is a Safety Class 1 Product (provided with a protective earthing ground incorporated in the power cord). The mains plug shall only be inserted in a socket outlet provided with a protective earth contact. Any interruption of the protective conductor inside or outside of the instrument is likely to make the instrument dangerous. Intentional interruption is prohibited.

WARNING

Electrostatic discharge (ESD) can damage or destroy electronic components. All work on electronic assemblies should be performed at a static-safe workstation.

CAUTION

VENTILATION REQUIREMENTS: When installing the product in a cabinet, the convection into and out of the product must not be restricted. The ambient temperature (outside the cabinet) must be less than the maximum operating temperature of the product by 4° C for every 100 watts dissipated in the cabinet. If the total power dissipated in the cabinet is greater than 800 watts, then forced convection must be used.

CAUTION

This product is designed for use in Installation Category II and Pollution Degree 2 per IEC 1010-1 and 664 respectively.

Installation Category: Installation Categories (overvoltage categories) are determined by the transient overvoltage levels that may be expected. CAT I: Mains isolated. CAT II: Line voltage in appliance and to wall outlet. CAT III: Line voltage behind wall outlet to next level of distribution.

Installing the 86130A

Before installing the 86130A, review the following specifications:

Table 1-1. Specifications Related to Installation

Use	Indoor
Temperature	
Operating	10 °C to +45 °C (50 °F to + 113 °F)
Non-operating	-40 °C to +70 °C (-40 °F to +158 °F)
Humidity	
Operating	Up to 95% humidity (non-condensing) at +40 °C (+104 °F), 5 day soak
Non-operating	Up to 90% relative humidity at + 65 °C (+149 °F), 24 hours
Shock (type tested)	
Operating	30 g (half sine), 11 msec pulse
Vibration (type tested)	
Operating	Random, 0.21 g rms 5 to 500 Hz, 10 minutes per axis Sine, 0.5 g (0 to peak) 5 to 500 Hz, 1 octave/min.
EMC	
Operating	Conducted and radiated interference is in compliance with CISPR publication 11, IEC 801-2, IEC 801-3, IEC 801-4, and IEC 555-2
Power Requirements	
Voltage	90–264 VAC, 47–66 Hz
Power Consumption	< 500 VA
Weight	
Net	20 kg (50 lb)

Step 1. Inspect the shipment

Table 1-1. Specifications Related to Installation

Dimensions	
Height	215 mm
Width	426 mm
Depth	527 mm

Step 1. Inspect the shipment

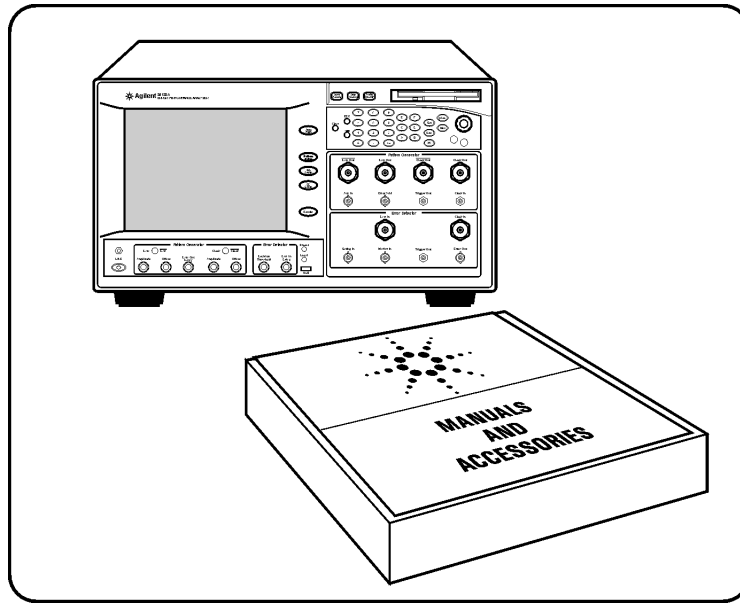

- Inspect the shipping container for damage.
- Inspect the instrument.
- Find the 86130A shipping list. Verify that you received all the accessories on this list, and all the options that you ordered.

The following table lists some of the accessories that may be on the 86130A shipping list. The information on your actual shipping list is more accurate and should supersede the information in this table.

Table 1-2. Supplied Accessories

Accessory	Agilent Part Number
Agilent 86130A Quick Start Guide	86130-90050
Agilent 86130A Quick Reference Card	86130-90053
CD ROM	86130-90052
Windows NT kit	9010-0211
Certificate of Calibration	5962-0476
USB Mouse	1150-7810
USB Keyboard	1150-7788
Stylus 3 pack	1535-5213
ESD Kit	9300-1484
Cable, SMA 3.5-mm Male Connectors (quantity: 3)	8120-4948
Power Cord	depends on country
Parallel Port Adapter (DB25/MC36)	1253-4226

The following table lists the accessories that are installed on the instrument. These may not be included on the 86130A shipping list.

Table 1-3. Accessories Installed on the Instrument

Adapter	Agilent Part Number
APC-3.5 mm Connector Savers (f-f) (quantity: 6)	5061-5311
APC-3.5 mm Terminations (50 ohms) (quantity: 9)	1250-2153

Step 1. Inspect the shipment

The following table lists the available product options. Make sure that you received all of the options that you ordered.

Table 1-4. Product Options

Option	Description
0B1	Agilent 86130A Programmer's Manual, hardcopy
100	2-D Error Mapping Analysis ^a
200	Error Correction Coding Analysis ^a
300	8648D 4.0 GHz External Synthesizer
AX4	Rack mount flange kit
AXE	Rack mount flange kit with handles

a. The 2-D Error Mapping Analysis and Error Correction Coding Analysis options require the installation of a license file to operate. For more information, contact your local Agilent Technologies Sales Office. Refer to [“Agilent Technologies Service Offices”](#) on page 1-33.

Keep the shipping container and cushioning material until you have inspected the contents of the shipment for completeness and have checked the instrument mechanically and electrically.

If anything is missing or defective, contact your nearest Agilent Technologies Sales Office. Refer to [“Agilent Technologies Service Offices”](#) on page 1-33. If the shipment was damaged, contact the carrier, then contact the nearest Agilent Sales Office. Keep the shipping materials for the carrier's inspection. The Agilent Sales Office will arrange for repair or replacement at Agilent's option without waiting for claim settlement.

Step 2. Connect the keyboard and mouse

Connect the standard PC-compatible mouse and keyboard.

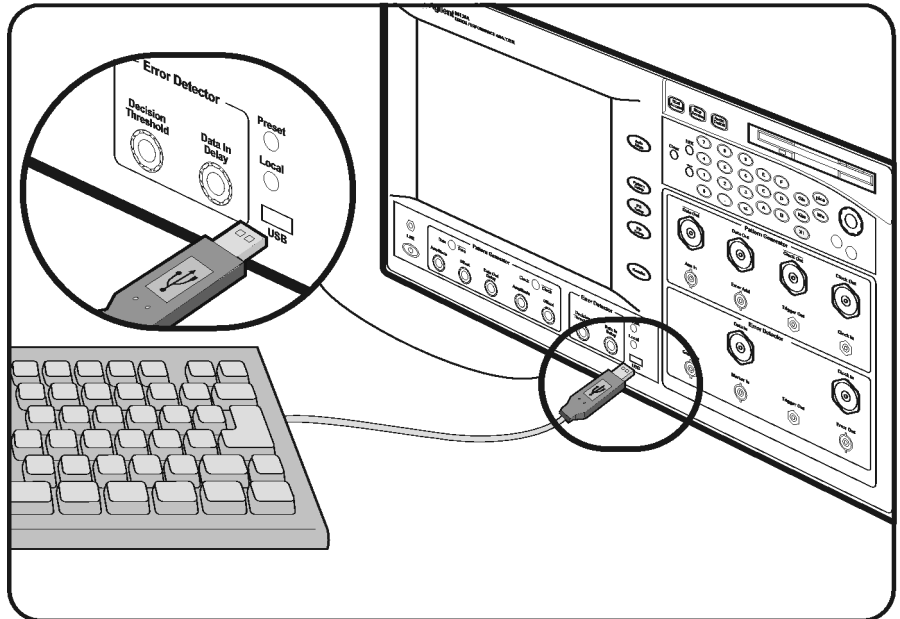

usbkeyboard.cdr

Although you can operate all instrument functions using a keyboard and mouse, the touch screen feature makes your 86130A even easier to use. The touch screen feature is always available, even when you connect the mouse. For more information, refer to [Chapter 4, “Using the Built-In Information System”](#).

Do *not* stack other objects on the keyboard; this will cause self-test failures on power-on.

Step 3. Connect the line cord

Step 3. Connect the line cord

The 86130A automatically adjusts for line input voltages in the range of 90 to 264 VAC. There is no manual selection switch. The line cord provided is matched by Agilent to the country in which the order originates. Refer to [Table 1-6, “Available Line Cords,”](#) on page 1-10 for a list of available line power cords.

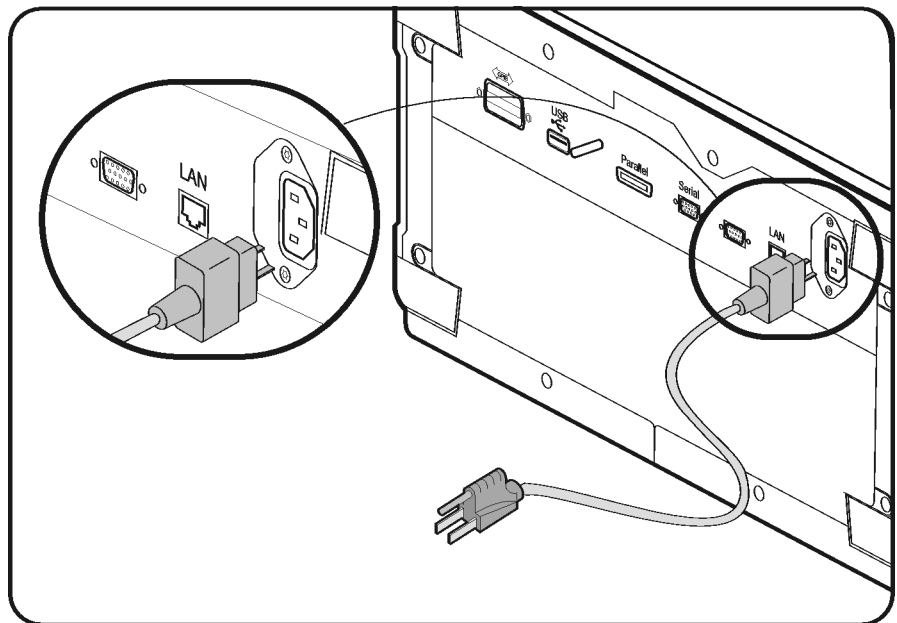

gs_linecord1.cdr

Note

Install the instrument so that the detachable power cord is readily identifiable and is easily reached by the operator. The detachable power cord is the instrument disconnecting device. It disconnects the mains circuits from the mains supply before other parts of the instrument. The front panel switch is only a standby switch and is not a LINE switch. Alternatively, an externally installed switch or circuit breaker (which is readily identifiable and is easily reached by the operator) may be used as a disconnecting device.

CAUTION

Always use the three-prong AC power cord supplied with this instrument. Failure to ensure adequate earth grounding by not using this cord may cause instrument damage.

CAUTION

Do not connect ac power until you have verified the line voltage is correct as described in [Table 1-5](#). Damage to the equipment could result.

CAUTION





This instrument has autoranging line voltage input. Be sure the supply voltage is within the specified range.

Table 1-5. Power Requirements

Voltage	90–264 VAC
Power Consumption	< 500 VA
Frequency	47–66 Hz

Setting Up the 86130A
Step 3. Connect the line cord

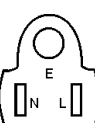
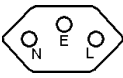
Table 1-6. Available Line Cords

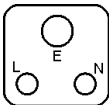
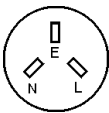
Plug Type	Cable Part No.	Plug Description	Length (in/cm)	Color	Country
250V 	8120-1351C	Straight *BS1363A	90/228	Gray	United Kingdom, Cyprus, Nigeria, Zimbabwe, Singapore
	8120-8705	90°	90/228	Mint Gray	
250V 	8120-1369C	Straight *NZSS198/ASC	79/200	Gray	Australia, New Zealand
	8120-0696	90°	87/221	Mint Gray	
250V 	8120-1689C	Straight *CEE7-Y11	79/200	Mint Gray	East and West Europe, Saudi Arabia, So. Africa, India (unpolarized in many nations)
	8120-1692	90°	79/200	Mint Gray	
125V 	8120-1378C	Straight *NEMA5-15P	90/228	Jade Gray	United States, Canada, Mexico, Philippines, Taiwan
	8120-1521	90°	90/228	Jade Gray	
250V 	8120-2104C	Straight *SEV1011	79/200	Mint Gray	Switzerland
	8120-2296	1959-24507 Type 12 90°	79/200	Mint Gray	
220V 	8120-2956C	Straight *DHCK107	79/200	Mint Gray	Denmark
	8120-2957	90°	79/200	Mint Gray	
250V 	8120-4211	Straight SABS164	79/200	Jade Gray	Republic of South Africa India
	8120-4600	90°	79/200	Jade Gray	
250V 	8120-5181	Straight	79/200	Gray	Israel

* Part number shown for plug is the industry identifier for the plug only. Number shown for cable is the Agilent part number for the complete cable including the plug.

Table 1-6. Available Line Cords

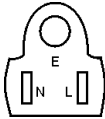
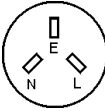
Plug Type	Cable Part No.	Plug Description	Length (in/cm)	Color	Country
100V 	8120-4753C	Straight MITI	90/230	Dark Gray	Japan
	8120-4754	90°	90/230		
250V 	8120-5181	Straight	79/200	Gray	Israel

* Part number shown for plug is the industry identifier for the plug only. Number shown for cable is the Agilent part number for the complete cable including the plug.

Setting Up the 86130A
Step 4. Turn on the line power

Step 4. Turn on the line power

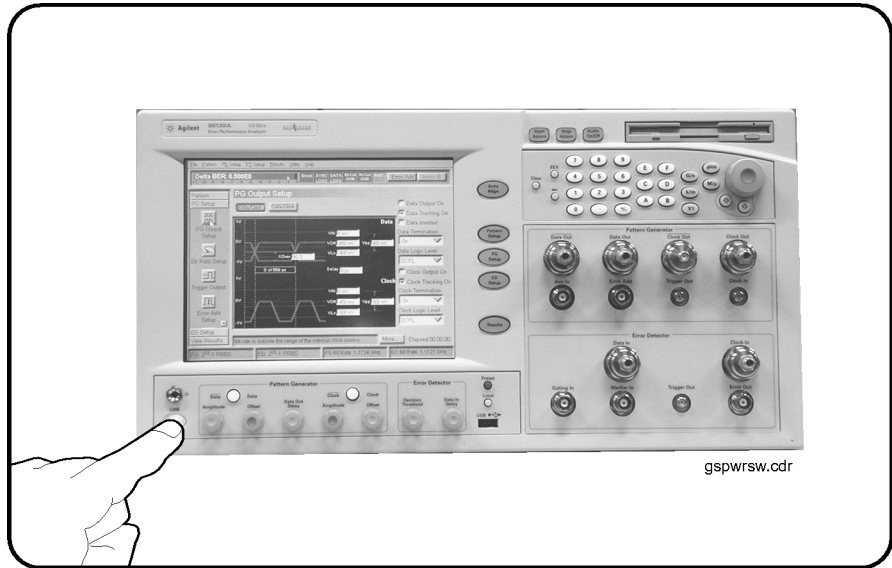

CAUTION

Before switching on this instrument, make sure the correct fuse is installed and that the supply voltage is in the specified range.

Press the power switch at the lower left-hand corner of the front panel.

After about one minute, the display will look similar to the following figure. The 86130A is ready to use.

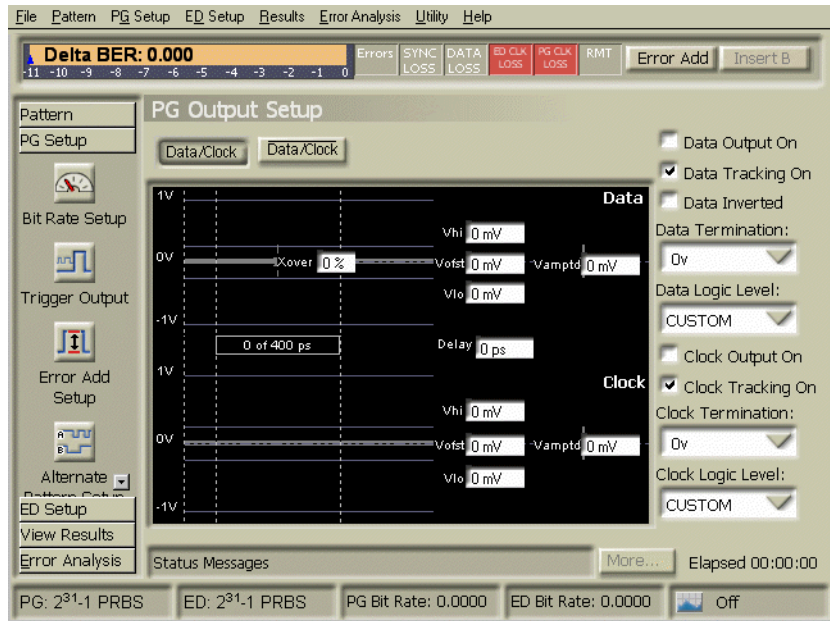

Step 5. Set the time and date

To set the time and date of your instrument, do the following:

Step 5. Set the time and date

- 1 On the **Utility** menu, click/touch **Set Date and Time**.

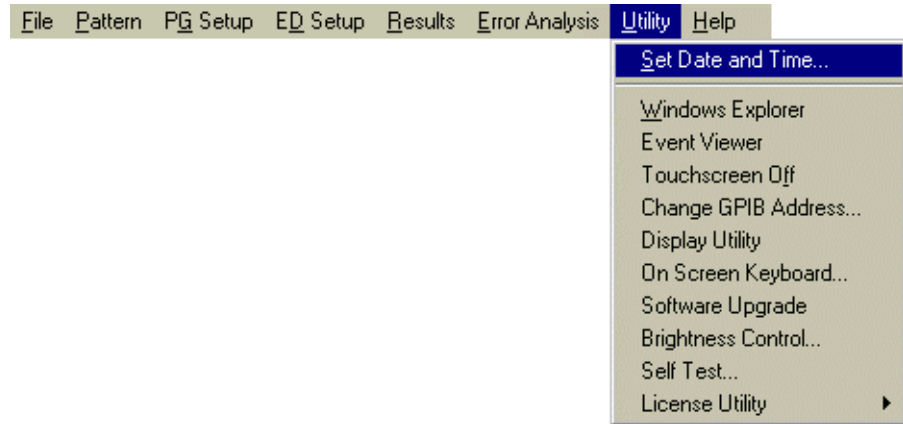

- 2 The **Date/Time Properties** dialog box should open. Set the time and date.
- 3 Click/touch **OK**.

CAUTION

Avoid touching the screen with a sharp object as this could result in damage to the display.

Step 6. Connect a printer

Use of a printer with the 86130A is optional. [Table 1-7](#) lists the PCL-language printers that are currently supported for use with the instrument. You must use the Add Printer Wizard to select the printer driver for the printer as outlined in this procedure; the Add Printer Wizard does not run automatically. For more information on connecting and using a printer, refer to the built-in information system.

Unsupported printers

If your printer is not in the list of supported printers, you will need the printer driver disk that came with your printer. To install the printer driver from this disk, click **Have Disk** on the **Add Printer Wizard** dialog box. The instrument will then prompt you to put your printer driver disk into the front-panel disk drive (drive A). Be sure to install the Windows NT printer driver for your printer. If a printer driver disk was not provided or you cannot find the disk, you can contact the printer's manufacturer to obtain the appropriate Windows NT printer driver.

Table 1-7. Supported Printers

HP DeskJet 850	HP DeskJet 1600C
HP DeskJet 890C	HP LaserJet 4P
HP DeskJet 970	HP LaserJet 4000N
HP DeskJet 1200C	

Step 6. Connect a printer

To connect a printer

- 1 Connect the printer to the instrument's rear-panel parallel port. Use the cable that came with your printer.

NOTE

If your printer cable does not have a mini-Centronics connector, you will have to use a DB25/MC36 adapter.

- 2 On the **File** menu, click/touch **Print Setup** then **Add Printer**.

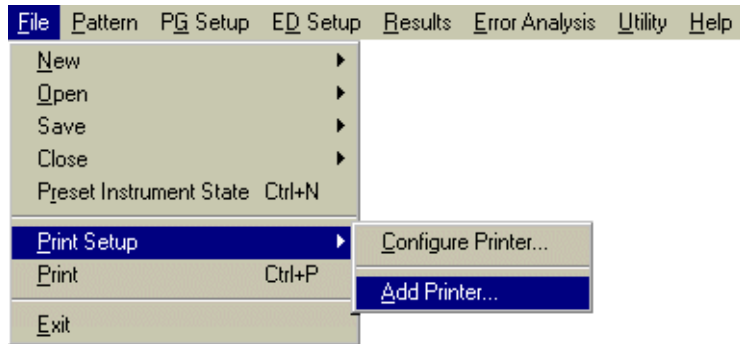

- 3 The **Add Printer Wizard** dialog box should open. Click/touch **My Computer** for a local printer installation or **Network printer server** for a printer connected to another server.
- 4 Follow all instructions in the **Add Printer Wizard**.

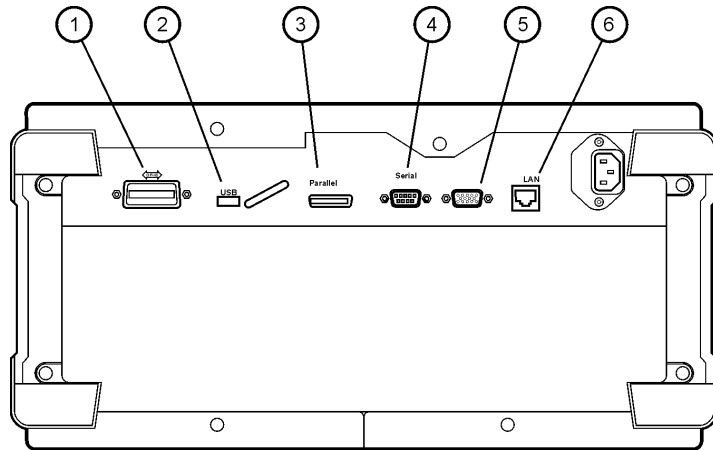

anote_rear

Table 1-8.

#	Rear Panel Feature
1	GPIB
2	USB Port
3	Parallel Port (Mini Centronics)
4	Serial Port
5	Display
6	LAN

Step 7. Configure the touch screen

Step 7. Configure the touch screen

CAUTION

Avoid touching the screen with a sharp object as this could result in damage to the display.

NOTE

For selections that are above or below your eye level, you may wish to direct your touch slightly above or below the intended target.

The touch screen configuration utility ensures that the touch screen is both aligned and oriented with the display. It also allows you to adjust the touch screen speed to simulate a double-click and to turn the touch screen sound on or off. You can change the behavior of the touch screen by choosing Touch Screen Config from the Utility menu. The Configuration Utilities dialog box opens and allows you to do the following:

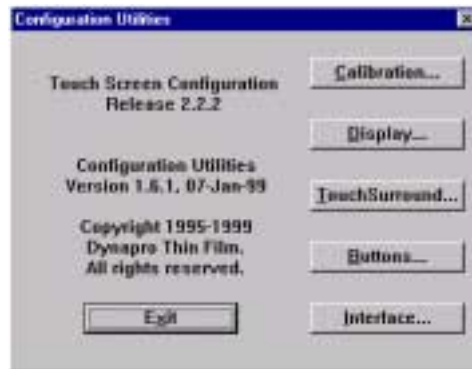

Calibrate the Touchscreen

In normal usage, you should not need to calibrate the touch screen display. But, if you feel that it needs to be realigned with the video display, you can click/touch Calibration on the Configuration Utilities dialog box. This opens the Calibration dialog box. When you click/touch Calibrate, a blank screen with a target will appear. Click/touch the target to start the calibration. When the calibration is complete, the calibration window will close.

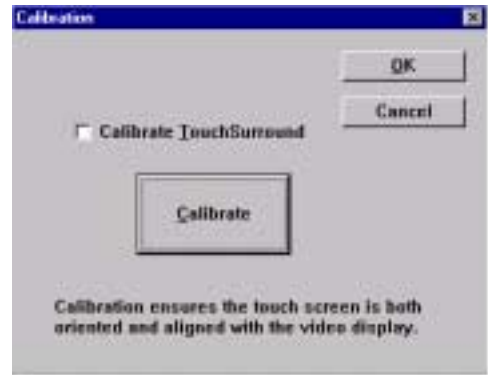

Adjust the Double Click

You can adjust the behavior of the touch screen display to simulate the double-click action of a typical personal computer or trackball. To configure the touch settings, click/touch Display on the Configuration Utilities dialog box. The Display Area Configuration dialog box opens. Click/touch the Timed Double Touch slide bar to adjust the amount of time that can pass as you touch the display screen. You can preview your adjustment by clicking/touching the Test Box.

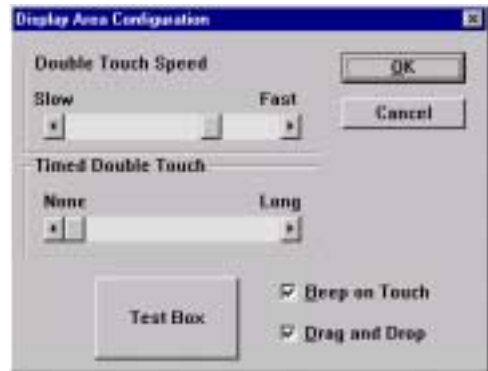

Beep on Touch

You can turn the touch screen sound on or off. Click/touch Display on the Configuration Utilities dialog box. The Display Area Configuration dialog box opens. Select the Beep on Touch check box to turn the touch screen sound on; clear the check box to turn the touch screen sound off.

Setting Up the 86130A

Step 7. Configure the touch screen

Touchscreen Off

You can disable the touch screen, keyboard, and mouse. On the **Utility** menu, click/touch **Touchscreen Off**.

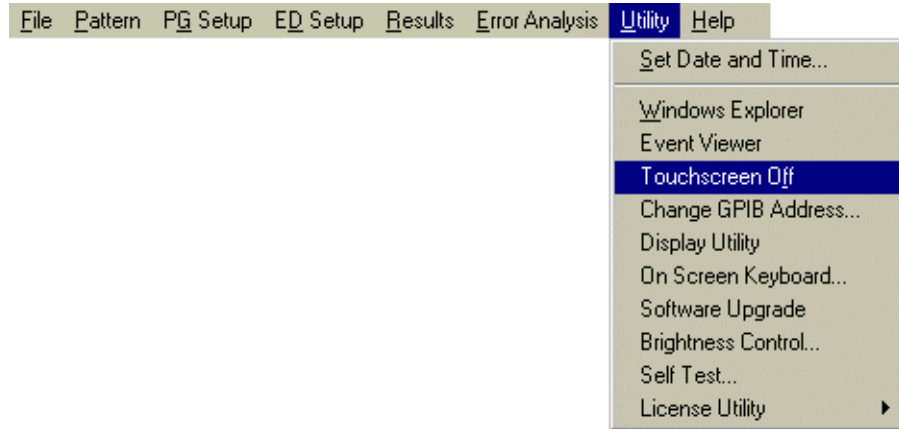

To indicate that these functions have been disabled, an icon is placed in the upper right hand corner of the instrument display. Click/touch the icon to enable the touch-screen, keyboard, and mouse again.



Step 8. Avoid costly repairs

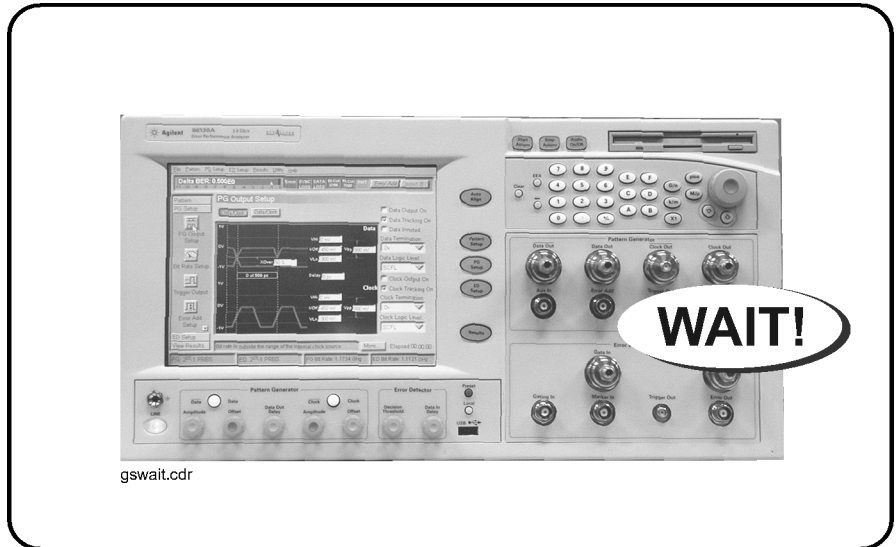

CAUTION

Electrostatic discharge (ESD) can damage or destroy electronic components. Coaxial cables with both ends unconnected may store electrostatic charges. Before connecting any coaxial cable of this sort to a device or instrument, momentarily short the center and outer conductors of the cable. When making connections, ensure the proper use of a grounded, resistor-isolated wrist strap.

Step 9. Perform a quick confidence check

Step 9. Perform a quick confidence check

To verify the basic functionality of the BitAlyzer, follow these steps:

- 1 Connect the power cord and turn the instrument on.
- 2 Press the green **Preset** button.



- 3 Connect the pattern generator clock and data to the error detector clock and data respectively, with APC-3.5 coax cables on the front panel.

Use a static strap when connecting APC-3.5 coax cables.

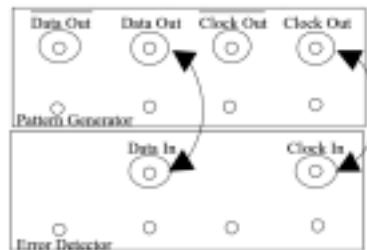

- 4 Turn on the pattern generator data and clock outputs. Press  and select the **Clock Output On** and **Data Output On** check boxes.



- 5 Press .

- 6 Check the **Delta BER** indicator. After fluctuating for some time during the auto

Step 9. Perform a quick confidence check

align, the red bar should turn blue, indicating the instrument is running error free.

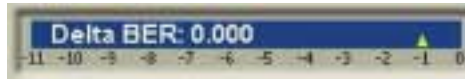

- 7 To make the pattern generator insert an error, click/touch the **Error Add** box in the upper right hand corner of the screen.



- 8 Confirm that the error detector detected the error. The Error indicator will flash momentarily to indicate the 86130A detected the error.

**If the verification check fails**

If the Agilent 86130A BitAnalyzer does not pass the confidence test, please make the following checks before calling Agilent Technologies or returning your unit for service:

- Is the unit plugged into the proper ac power source?
- Is the line fuse good?
- Is the unit turned on? Verify the line switch is green, indicating the power supply is on.
- Check your coax cables for shorts or opens; replace as necessary.
- Review the procedure for the confidence check. Press **Preset** again, and start from the beginning.

If the instrument still fails, refer to [refer to “Returning the Instrument for Service” on page 1-30.](#)

Step 10. Configure for Bench Top or Rack Mount Use

Table 1-9.

Option	Description
86130A AX4	Rack Flange Kit
86130A AXE	Rack Flange Kit with Handles

To Attach Rack Mount to the Agilent 86130A

- 1 Ensure that the rack mount kit is complete.

Table 1-10.

Qty	Description
2	Rack Mount Flange
6	Screws
4	Dress screws
2	Front Handle Assembly (Option AXE only)

If any items are damaged or missing from the kit, contact the nearest Agilent Technologies sales or service office to order a replacement kit. Items within the kit are not individually available.

- 2 Remove the side trim strips.
- 3 Attach rack mount flange with three screws per side.

WARNING

Use only the screws the come with the rack mount kit. Longer screws may damage the instrument, and shorter screws may be unsafe.

- 4 Remove feet before rack mounting.

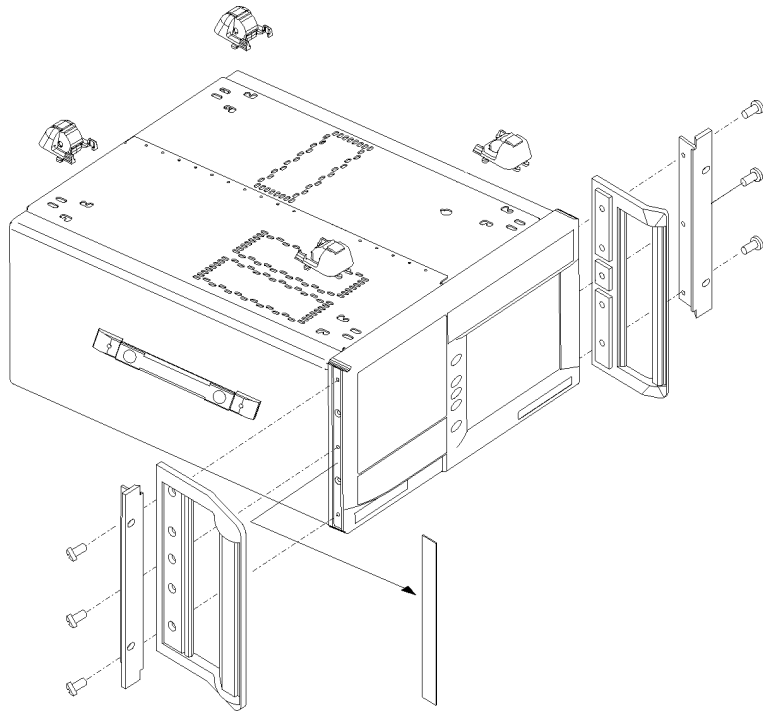

Front Handle Assembly are included with Option AXE only.

Step 11. For more information

To learn more about Agilent Technologies products, visit our website at <http://www.agilent.com>.

If you wish to find out more about your new bit error ratio tester, use the keyword “86130A” in your search.

Cleaning Connections for Accurate Measurements

Today, advances in measurement capabilities make connectors and connection techniques more important than ever. Damage to the connectors on calibration and verification devices, test ports, cables, and other devices can degrade measurement accuracy and damage instruments. Replacing a damaged connector can cost thousands of dollars, not to mention lost time! This expense can be avoided by observing the simple precautions presented in this book.

Caring for Electrical Connections

The following list includes the basic principles of microwave connector care:

Handling and storage

- Keep connectors clean
- Extend sleeve or connector nut
- Use plastic endcaps during storage
- Do *not* touch mating plane surfaces
- Do *not* set connectors contact-end down

Visual inspection

- Inspect all connectors carefully before every connection
- Look for metal particles, scratches, and dents
- Do *not* use damaged connectors

Cleaning

- Clean with compressed air first
- Clean the connector threads
- Do *not* use abrasives
- Do *not* get liquid onto the plastic support beads

Making connections

- Align connectors carefully
- Make preliminary connection lightly
- To tighten, turn connector nut *only*
- Do *not* apply bending force to connection
- Do *not* over tighten preliminary connection
- Do *not* twist or screw in connectors
- Do *not* tighten past the “break” point of the torque wrench

Inspecting Connectors

Before using connectors for a critical application, inspect the connector interfaces with a microscope (~20X). Look for dirt, contaminants, dented or scratched outer conductor mating surfaces, and damaged center conductors.

Inspecting SMA connectors

You must carefully inspect an SMA connector prior to mating with a precision 3.5mm connector (this includes a new SMA connector). This must be both a visual and mechanical inspection. Use a precision connector gauge designed to measure SMA connectors. Remember that gauging SMA connectors is the most important step you can take to prevent damaging your equipment.

A male SMA connector pin that is too long can smash or break the delicate fingers on the precision 3.5mm female connector.

Cleaning RF Connectors

The procedures in this section provide the proper steps for cleaning RF connectors. The initial cleaning, using alcohol as a solvent, gently removes any grit and oil. If a caked-on layer of material is still present, a second cleaning should be performed. It is not uncommon for a cable or connector to require more than one cleaning.

CAUTION

Agilent Technologies strongly recommends that index matching compounds *not* be applied to their instruments and accessories. Some compounds, such as gels, may be difficult to remove and can contain damaging particulates. If you think the use of such compounds is necessary, refer to the compound manufacturer for information on application and cleaning procedures.

Table 1-11. Cleaning Accessories

Item	Agilent Part Number
Isopropyl alcohol	8500-5344
Cotton swabs	5080-5400
Compressed Air	8500-6659
Lint free cloth (one)	9310-4242
Connector care quick reference card	08510-90360

Table 1-12. Dust Caps Provided with Lightwave Instruments

Item	Agilent Part Number
Laser shutter cap	08145-64521
FC/PC dust cap	08154-44102
DIN dust cap	08154-44103
HMS 10/HP dust cap	08154-44101

To clean an RF connector

- 1** Use a swab dipped in clean isopropyl alcohol to clean off the outer conductor mating surfaces and the ends of the center conductors. Be careful not to let the alcohol get on the insulator bead, as this may damage the bead. Be careful not to exert too much force on the center conductors, especially slotless female center conductors, as they may be damaged. Use a swab that has a sharp enough corner to clean all areas of the connector interface. Don't forget to clean off the coupling nut threads.
- 2** Blow off the alcohol with clean compressed air. Compressed air can reduce the temperature of connectors dramatically, and this can have a significant effect upon

the performance of calibration and verification components. If the connector components being cleaned are to be used in a critical measurement application, the temperature of these components should be allowed to stabilize before they are used.

- 3** Reinspect the connectors under the microscope. If the outer conductor mating face of a connector has raised material that would keep it from making complete contact with another connector, it should be replaced. If the fingers of a slotted female contact are spread open, rather than crimped closed, the connector should be replaced. If a connector has a slotless contact with damaged fingers, the connector should be repaired or replaced.

Returning the Instrument for Service

NOTE

To power down the instrument, press the line button once. If you press it more than once, the instrument will restart.

The instructions in this section show you how to properly package the instrument for return to an Agilent Technologies service office. For a list of offices, [refer to “Agilent Technologies Service Offices” on page 1-33.](#)

If the instrument is still under warranty or is covered by an Agilent maintenance contract, it will be repaired under the terms of the warranty or contract (the warranty is at the front of this manual). If the instrument is no longer under warranty or is not covered by an Agilent maintenance plan, Agilent will notify you of the cost of the repair after examining the unit.

When an instrument is returned to a Agilent service office for servicing, it must be adequately packaged and have a complete description of the failure symptoms attached.

When describing the failure, please be as specific as possible about the nature of the problem. Include copies of additional failure information (such as the instrument failure settings, data related to instrument failure, and error messages) along with the original cal data disks and the instrument being returned.

Please notify the service office before returning your instrument for service. Any special arrangements for the instrument can be discussed at this time. This will help the Agilent service office repair and return your instrument as quickly as possible.

Preparing the instrument for shipping

- 1 Write a complete description of the failure and attach it to the instrument. Include any specific performance details related to the problem. The following information should be returned with the instrument:
 - Type of service required
 - Date instrument was returned for repair
 - Description of the problem:
 - Whether problem is constant or intermittent
 - Whether instrument is temperature-sensitive
 - Whether instrument is vibration-sensitive
 - Instrument settings required to reproduce the problem
 - Performance data
 - Company name and return address
 - Name and phone number of technical contact person
 - Model number of returned instrument
 - Full serial number of returned instrument
 - List of any accessories returned with instrument
 - The original cal data disks
- 2 Cover all front or rear-panel connectors that were originally covered when you first received the instrument.

CAUTION

Cover electrical connectors to protect sensitive components from electrostatic damage. Cover optical connectors to protect them from damage due to physical contact or dust.

CAUTION

Instrument damage can result from using packaging materials other than the original materials. Never use styrene pellets as packaging material. They do not adequately cushion the instrument or prevent it from shifting in the carton. They may also cause instrument damage by generating static electricity.

- 3 Pack the instrument in the original shipping containers. Original materials are available through any Agilent office. Or, use the following guidelines:
 - Wrap the instrument in antistatic plastic to reduce the possibility of damage caused by electrostatic discharge.
 - For instruments weighing less than 54 kg (120 lb), use a double-walled, corrugated cardboard carton of 159 kg (350 lb) test strength.
 - The carton must be large enough to allow approximately 7 cm (3 inches) on all

Preparing the instrument for shipping

sides of the instrument for packing material, and strong enough to accommodate the weight of the instrument.

- Surround the equipment with approximately 7 cm (3 inches) of packing material, to protect the instrument and prevent it from moving in the carton. If packing foam is not available, the best alternative is S.D-240 Air Cap™ from Sealed Air Corporation (Commerce, California 90001). Air Cap looks like a plastic sheet filled with air bubbles. Use the pink (antistatic) Air Cap™ to reduce static electricity. Wrapping the instrument several times in this material will protect the instrument and prevent it from moving in the carton.
- 4 Seal the carton with strong nylon adhesive tape.
 - 5 Mark the carton “FRAGILE, HANDLE WITH CARE”.
 - 6 Retain copies of all shipping papers.

Agilent Technologies Service Offices

Before returning an instrument for service, first call the Agilent Technologies Instrument Support Center at (800) 403-0801. If you continue to experience difficulty, please call one of the service numbers listed below.

Agilent Technologies Service Numbers

Austria	01/25125-7171
Belgium	32-2-778.37.71
Brazil	(11) 7297-8600
China	86 10 6261 3819
Denmark	45 99 12 88
Dominican Republic	(809) 563-6350
Finland	358-10-855-2360
France	01.69.82.66.66
Germany	0180/524-6330
India	080-34 35788
Italy	+39 02 9212 2701
Ireland	01 615 8222
Japan	(81)-426-56-7832
Korea	82/2-3770-0400
Mexico	(5) 258-4826
Netherlands	020-547 6463
Norway	+47 22 73 57 59

Setting Up the 86130A
Agilent Technologies Service Offices

Agilent Technologies Service Numbers

Puerto Rico	(800) 403-0801
Russia	+7-095-797-3930
Spain	(34/91) 631 1213
Sweden	08-5064 8700
Switzerland	(01) 735 7200
Taiwan	(886 2) 2-712-0404
United Kingdom	01 344 366666
United States and Canada	(800) 403-0801

NOTE

To view numbers for more countries, see the built-in information system.

Working in Comfort

Working in Comfort

To optimize your comfort and productivity, it is important that you set up your work area correctly and use your Agilent product properly. With that in mind, we have developed some setup and use recommendations for you to follow based on established ergonomic principles.

Improper and prolonged use of keyboards and input devices are among those tasks that have been associated with repetitive strain injury (RSI) to soft tissues in the hands and arms. If you experience discomfort or pain while using your Agilent Technologies product, discontinue use immediately and consult your physician as soon as possible.

Please study the recommendations offered here in this chapter. You may also wish to consult your employer's human resources department or other relevant departments for guidance specific to your company.

About Repetitive Strain Injury

Because your comfort and safety are our primary concern, we strongly recommend that you use the Agilent 86130A in accordance with established ergonomic principles and recommendations. Scientific literature suggests that there may be a relationship between injury to soft tissues - especially in the hands and arms - and prolonged improper use of keyboards or other equipment requiring repeated motions of the hands and forearms. This literature also suggests that there are many other risk factors that may increase the chance of such injury, commonly called Repetitive Strain Injury.

What is RSI?

Repetitive Strain Injury (RSI—also known as cumulative trauma disorder or repetitive motion injury) is a type of injury where soft tissues in the body, such as muscles, nerves, or tendons, become irritated or inflamed. RSI has been a reported problem for those who perform repetitive tasks such as assembly line work, meatpacking, sewing, playing musical instruments, and computer work. RSI has also been observed in those who frequently engage in activities such as carpentry, knitting, housework, gardening, tennis, windsurfing and lifting children.

What causes RSI?

The specific causes of RSI have not been established. Nevertheless, the incidence of RSI has been associated with a variety of risk factors, including:

- Too many uninterrupted repetitions of an activity or motion.
- Performing an activity in an awkward or unnatural posture.
- Maintaining a static position for prolonged periods.
- Failing to take frequent short breaks.
- Other environmental and social factors.

In addition, there have been reports associating the occurrence of RSI with the use of keyboards, mice, and other input devices. Also, certain medical conditions, such as rheumatoid arthritis, obesity and diabetes, may predispose people to this type of injury.

Working in Comfort
About Repetitive Strain Injury

What if I experience discomfort? If you are experiencing any discomfort, seek professional medical advice immediately. Typically, the earlier a problem is diagnosed and treated, the easier it is to resolve.

Mice and Other Input Devices

Various aspects of using mice and other input devices may increase your risk of discomfort or injury. Observing the following recommendations may reduce that risk.

- Try to keep your hand, wrist and forearm in a neutral position while using your mouse or other input device.
- If you use your thumb to rotate the ball on a trackball or spaceball, keep it in a relaxed, natural shape and maintain a neutral posture in your hand, wrist and forearm.
- Hold the mouse gently by draping your fingers over it. Keep your hand relaxed and fingers loose. Do not grip the mouse tightly.
- It takes very little pressure or force from your fingers to activate the buttons or scroll wheel on your mouse, scrolling mouse, trackball or other input device. Using too much force can place unnecessary stress on the tendons and muscles in your hands, wrists and forearms.
- If you are using a scrolling mouse, be sure to keep your fingers and hand in a relaxed, neutral position when activating the scroll wheel. Also, this type of mouse features software that can minimize the number of mouse movements or button clicks.
- When using a mouse, trackball or other input device, position it as close to the keyboard as possible and keep it at the same level so you do not have to stretch while using it.
- Use a good quality mouse pad to enable the mouse to work most effectively and reduce unnecessary hand and wrist movements.
- Be sure to keep your mouse and trackball clean. Regular removal of accumulated dust and dirt helps ensure proper tracking and reduces unnecessary hand and wrist motions.

Working in Comfort
Mice and Other Input Devices

Introduction 3-2
Front and Rear Panel 3-4
Menus 3-7
On-Screen Keyboard 3-10

Using the Agilent 86130A

Introduction

Introduction

The Agilent 86130A is designed to quickly verify error performance. You can operate the instrument by using the touch screen and front panel controls.

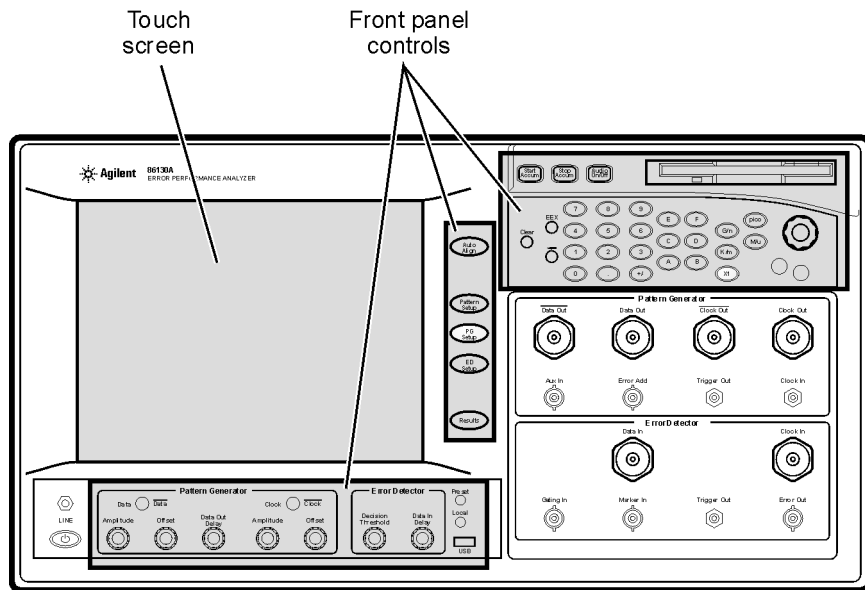

Use the touch screen

You can explore the instrument's menus and change its settings by touching the display.

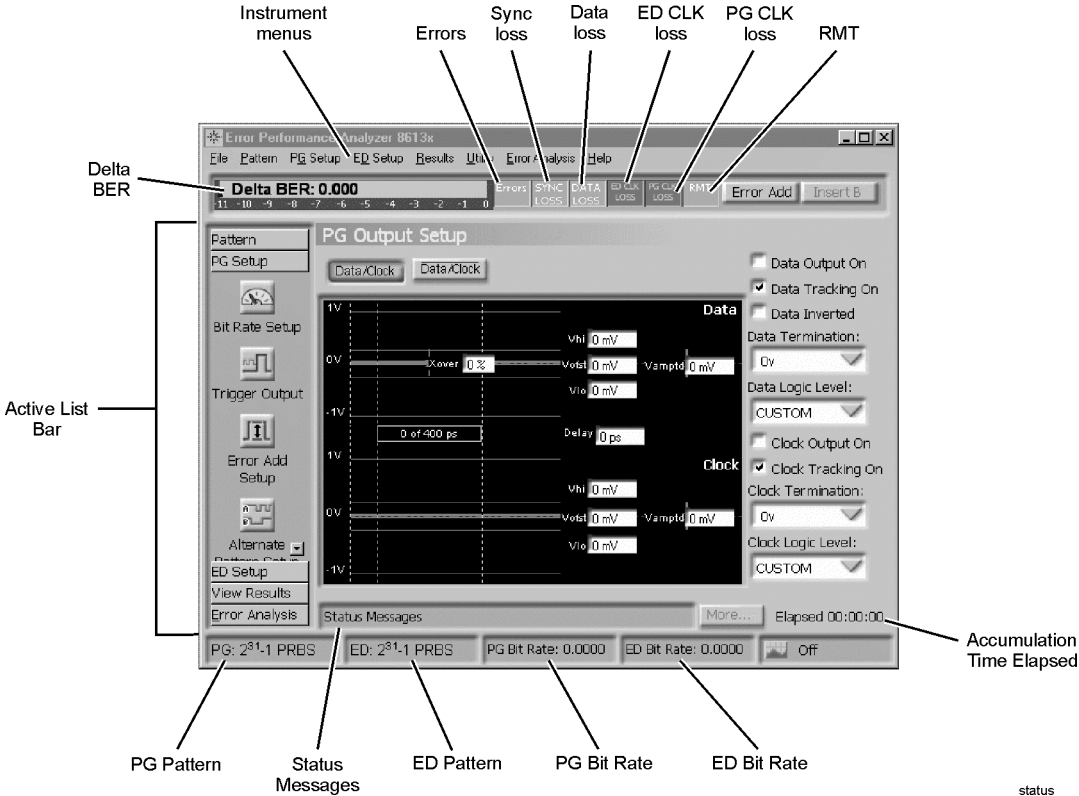

status

Refer to the built-in information system

To learn how to use your Agilent 86130A and to locate information on specifications, instrument functions, and measurement configuration, refer to [Chapter 4, "Using the Built-In Information System"](#) in this book.

Front and Rear Panel

The following table and corresponding figure show the input connectors, controls, power switch, and other front panel features available on the Agilent 86130A.

Table 3-1.

#	Front Panel Feature	#	Front Panel Feature	#	Front Panel Feature
1	Instrument Setups	9	Trigger Output	17	Aux In
2	Auto Align	10	Error Add	18	Results
3	Accumulation Controls	11	Clock In	19	USB Port
4	3.5-inch Disk Drive	12	Error Out	20	Local
5	Keypad and Front Panel Knob	13	Trigger Out	21	Preset
6	Data and Data Bar Outputs	14	Data In	22	Error Detector Controls
7	Clock and Clock Bar Outputs	15	Marker In	23	Pattern Generator Controls
8	Clock In	16	Gate In	24	Power

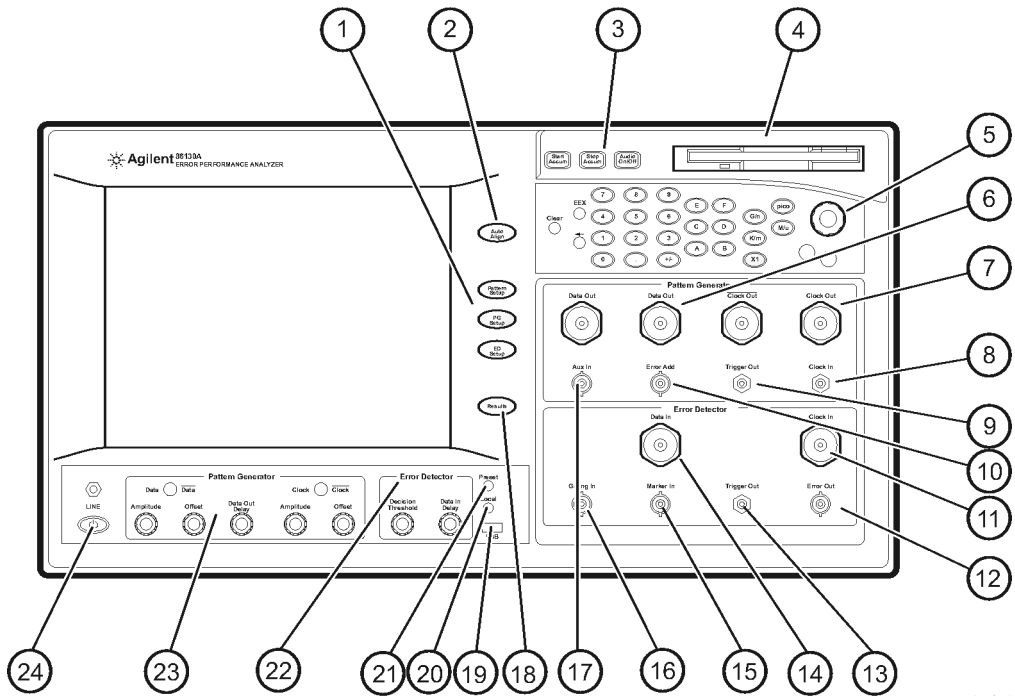

anote_frnt

Front and Rear Panel

Table 3-2.

#	Rear Panel Feature
1	GPIB
2	USB Port
3	Parallel Port (Mini Centronics)
4	Serial Port
5	Display
6	LAN

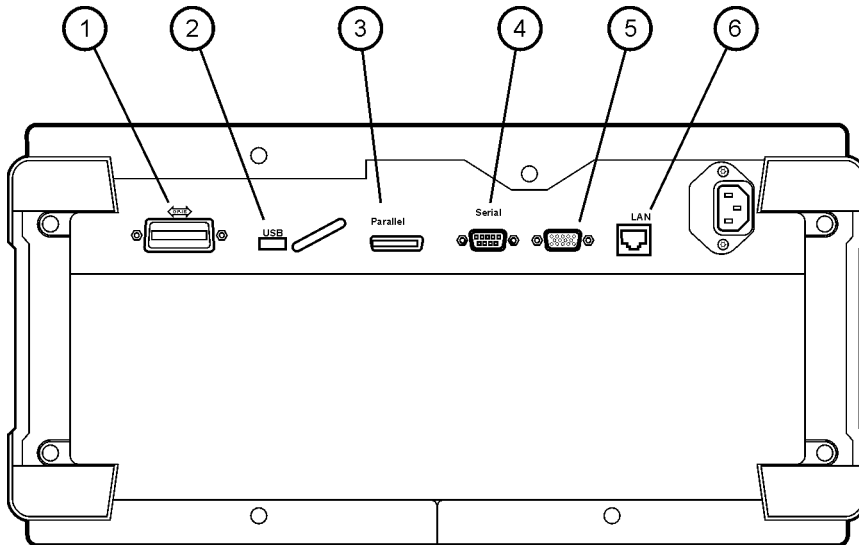

anote_rear

Menus

The main menu bar includes the **File**, **Pattern**, **PG Setup**, **ED Setup**, **Results**, **Utility**, **Error Analysis**, and **Help** menus. For detailed information on each of these menus, see the built-in information system.

File menu

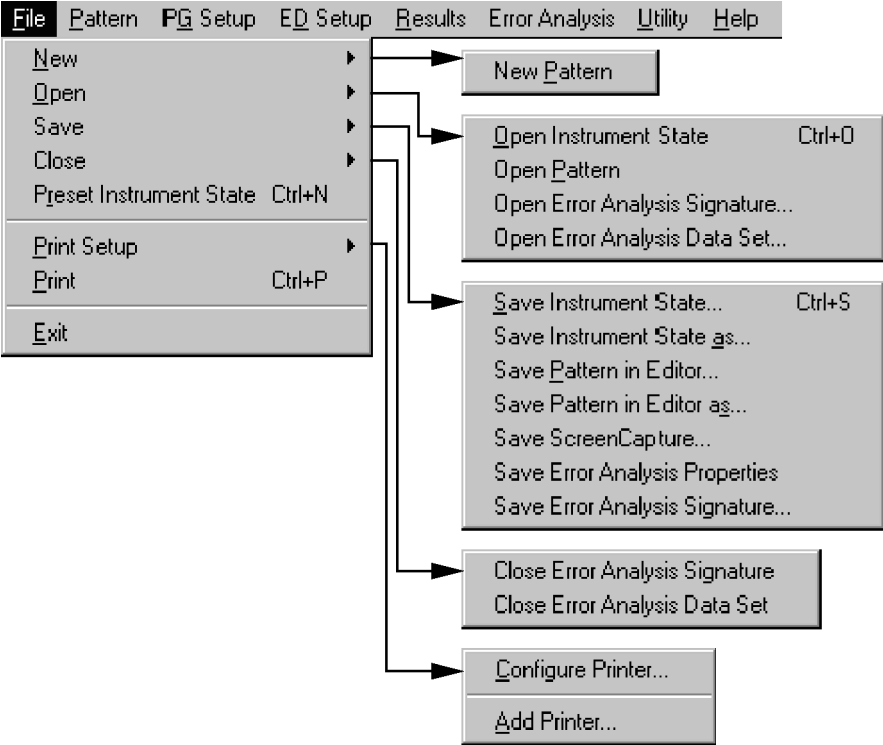

Menus

Pattern menu

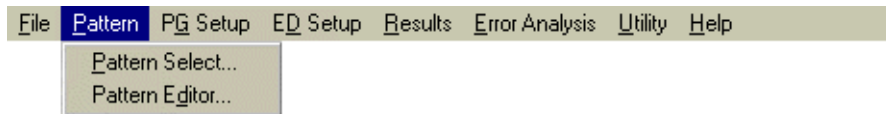

PG Setup menu

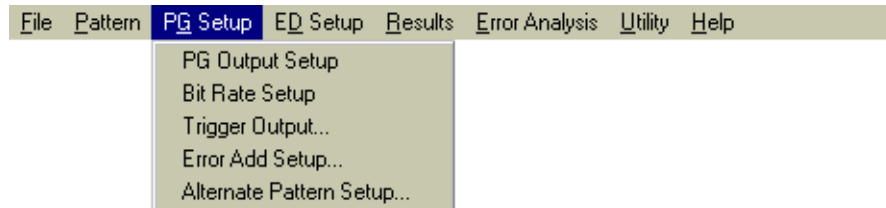

ED Setup menu

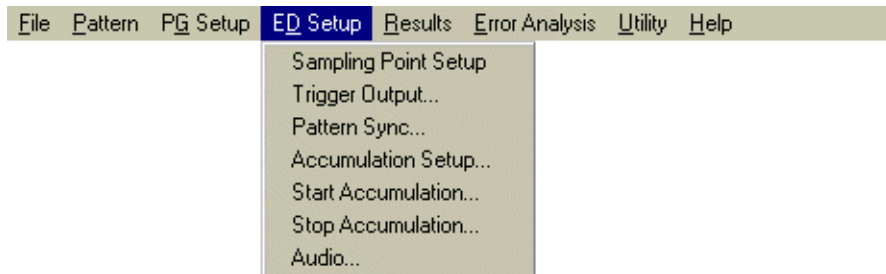

Results menu

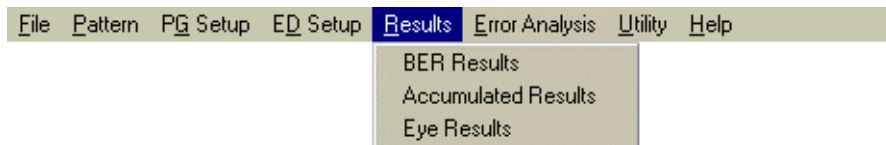

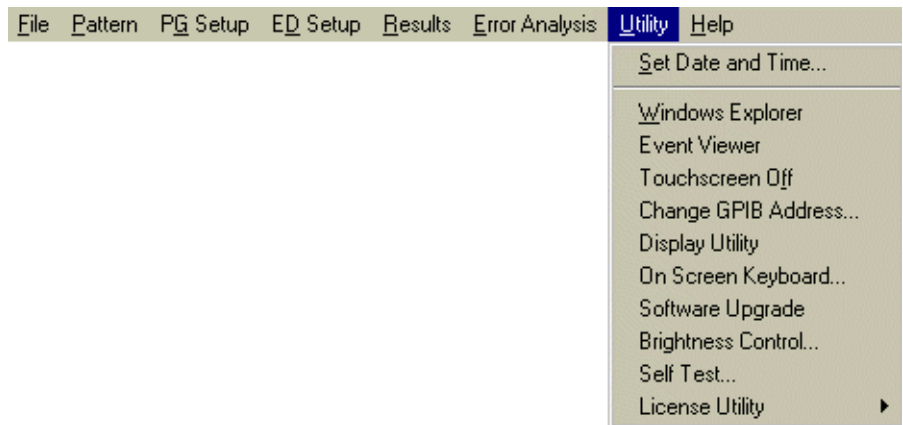
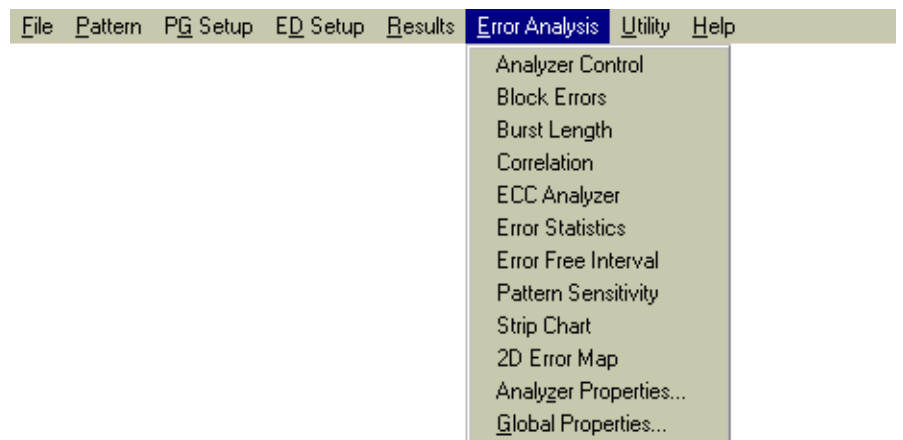
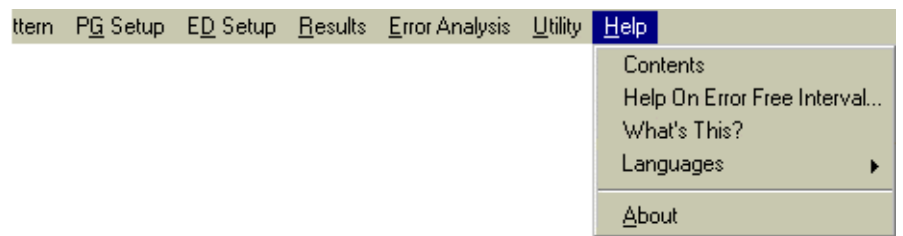
Utility menu**Error Analysis menu****Help menu**

On-Screen Keyboard

You can use the on-screen keyboard to enter text in any text box. It can be used along with the standard keyboard or keypad.

How to Access the On Screen Keyboard

Press the **On Screen Keyboard** button on the front panel

- or -

On the **Utilities** menu, click/touch **On Screen Keyboard**.

A check mark will appear next to the text on the **Utilities** menu, indicating that it has been selected.

For best results with the on-screen keyboard, use the following technique:

- 1 Click/touch to position the cursor in a text box.
- 2 Press the **On Screen Keyboard** button to open the on-screen keyboard.
- 3 Click/touch letters and numbers as desired to complete the entry.
- 4 Press the **On Screen Keyboard** button to close the on-screen keyboard .



NOTE

For your convenience, the on-screen keyboard can be configured in several ways. For more information, see the online Help topic **On Screen Keyboard Options**.

The Contents of the Built-In Information System 4-3
Learning How to Set Up the 86130A and Make BER Measurements 4-6
Getting Help From the Main Window or Dialog Box 4-7
Hiding the Built-in Information System 4-10
Printing the Contents of a Topic 4-11

Using the Built-In Information System

Using the Built-In Information System

Where is the operating manual for your Agilent 86130A? It is built into your instrument! To access the built-in information system, simply click/touch **Contents** on the **Help** menu. This will display the contents topic that is shown in the figure on the following page. In this chapter, you'll learn features that are unique to the Agilent 86130A's built-in information system as well as tips that will make the system more useful to you.

Navigating through the system should be familiar to you because it is similar to other Windows applications. You can, of course, navigate through the **Help** menu by either using the touch screen or the mouse.

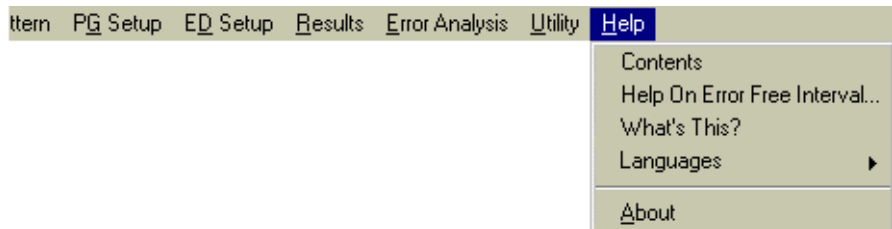

The Contents of the Built-In Information System

The following figure shows the contents for the built-in information system. This is the starting point for learning how to use your Agilent 86130A.

In addition to the nine topics presented in the contents, be sure to use the index buttons located along the bottom. These can be very helpful in locating a topic of interest.

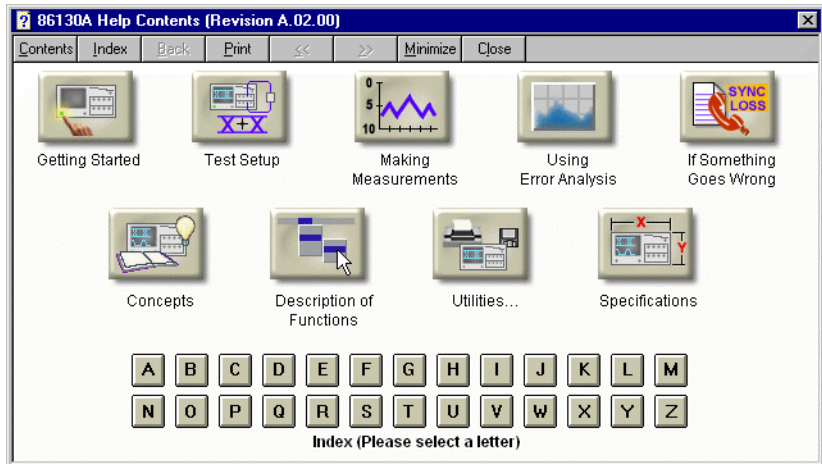

Description of the Contents Topics

The following list describes the information you can find in each of contents topics.



Getting Started

This topic contains links to useful information you may want to read first, such as ESD and ergonomic information.



Test Setup

This topic provides steps to prepare you for making accurate BER measurements.

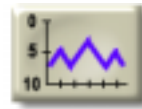

Making
Measurements

This topic provides information about how to make measurements, and how to view and analyze results.



Using
Error Analysis

This topic contains information about error location analysis, which is a tool for finding the cause of bit errors.

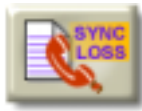

If Something
Goes Wrong

This topic provides links on how to troubleshoot, read error messages, and get more assistance.

Using the Built-In Information System
The Contents of the Built-In Information System



Concepts

This topic provides conceptual information about BER measurements.



Description of
Functions

This topic describes all instrument functions.



Utilities ...

This topic provides information on utilities, printing, and saving.



Specifications

This topic provides the 86130A Technical Specifications.

Learning How to Set Up the 86130A and Make BER Measurements

You can learn how to set up the 86130A by following the steps located in “Test Setup” topic. You can learn how to make measurements and view results from the information located in “Making Measurements” topic.

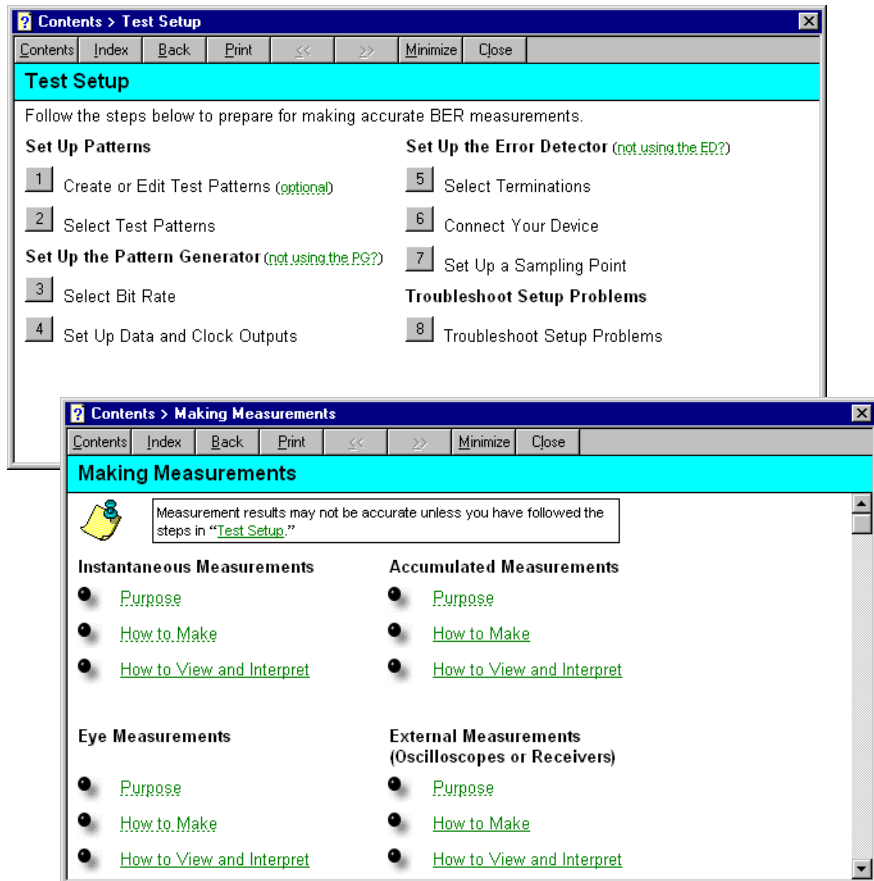

Getting Help From the Main Window or Dialog Box

Getting Help From the Main Window

When in the main window, you can get online Help directly from the **Help** menu. Click/touch **Help** and **Help on**. “Help on” gives tailored information on the screen or setup you are currently viewing.

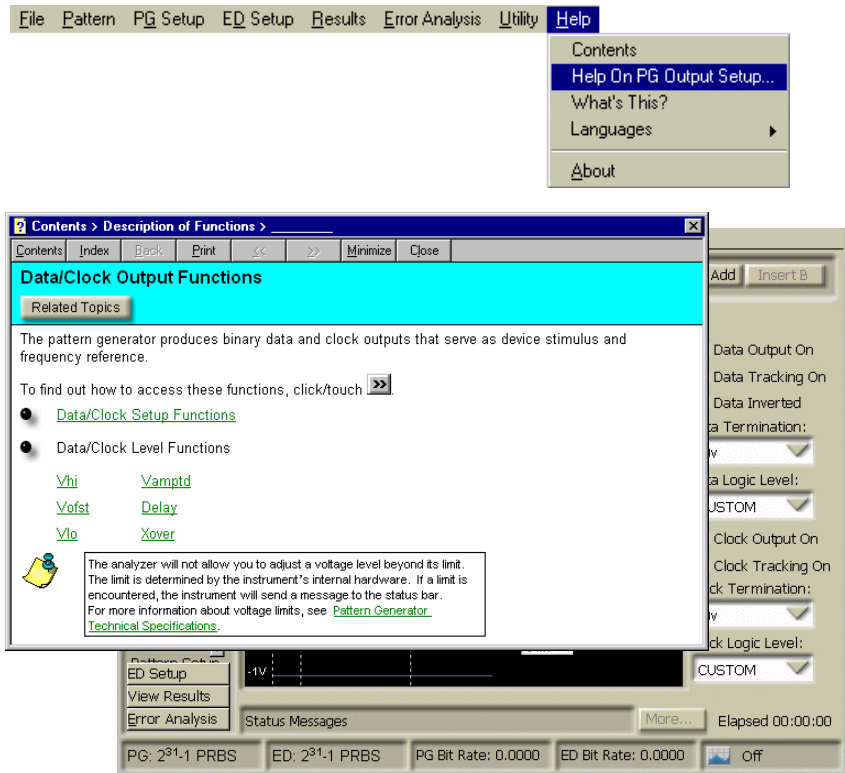

Getting Help From the Main Window or Dialog Box

Getting Help from What's This?

To get a description about a specific field, click/touch **What's This?** on the **Help** menu. A question mark will appear next to the pointer, indicating that **What's This?** is active. Position the question mark and pointer over the area of interest and click your mouse. A popup window will appear that explains the features of the area.

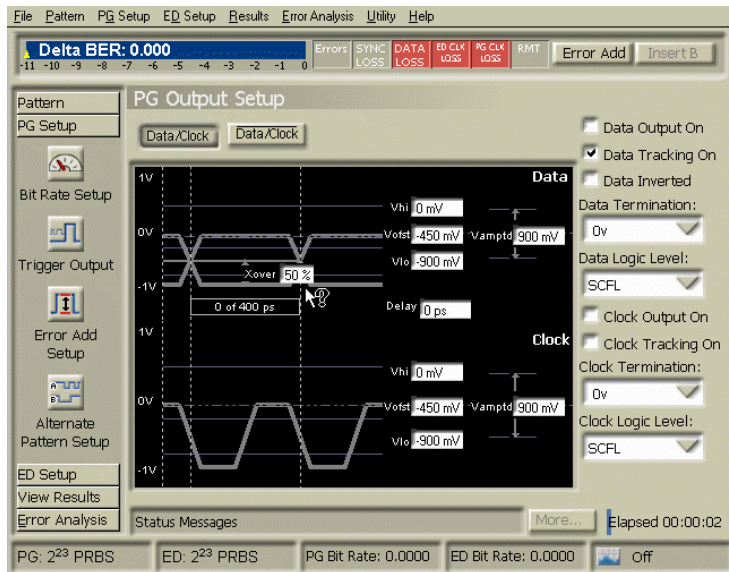
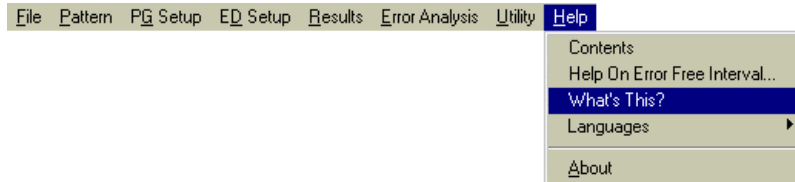

Getting Help From a Dialog Box

Online Help and What's This? help are available in dialog boxes.

- To access online Help, click/touch **Help**.
- To access What's This help, click/touch the **What's This?** icon.

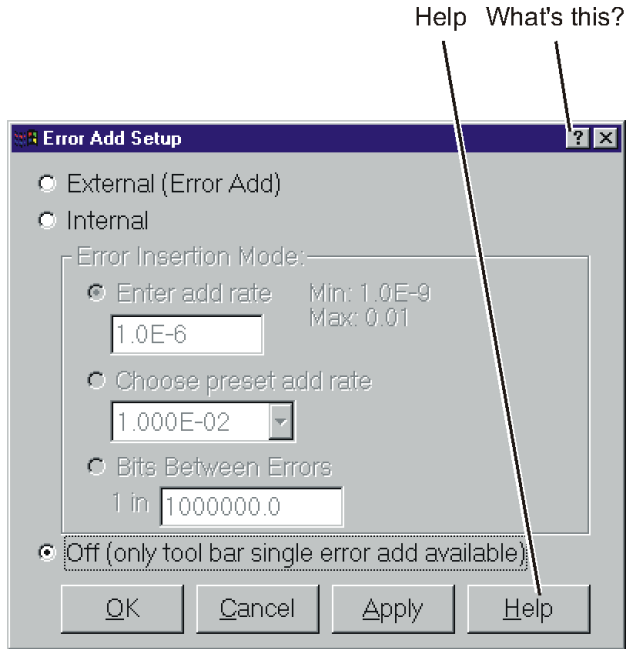

help.cdr

Hiding the Built-in Information System

When using the built-in information system, you can temporarily hide it so you can see the entire display. Then, you can re-display the built-in information system with the same topic still showing.

- To hide the built-in information system, click/touch the **Minimize** button located at the top of the built-in information system.



- To re-display the built-in information system, click/touch the **Restore** button that is shown on the display.



Printing the Contents of a Topic

You can print the entire contents of a help topic or a pop-up window.

- 1 Connect a printer and a mouse pointing device to the Agilent 86130A.
- 2 To print a topic, click/touch **Print** on the **Help** window. To print a popup window, place the pointer over the topic, and click the right button. Then click on **Print Topic**.



Selecting the Built-in Information System Language

Help is available in more than one language. On the Help menu, touch Select Help Language, and then touch the language you want to view. Please ensure that the Help file is closed before changing the language selection. You can only view one version of help at a time.

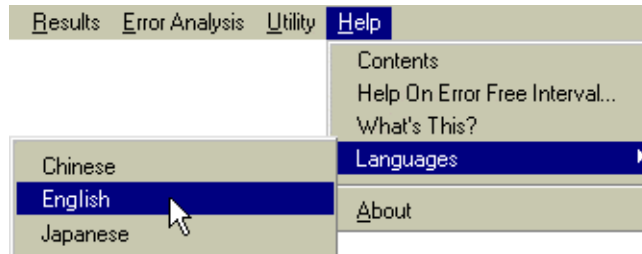

Help Version

Refer to the English version of help to view the most current information about instrument features and specifications.

Regulatory Information

Regulatory Information

DECLARATION OF CONFORMITY According to ISO/IEC Guide 22 and CEN/CENELEC EN 45014	
Manufacturer's Name:	Agilent Technologies, Inc.
Manufacturer's Address:	1400 Fountaingrove Parkway Santa Rosa, CA 95403-1799 USA
Declares that the product:	
Product Name:	BitAlyzer® Error Performance Analyzer
Model Number:	86130A
Product Options:	This declaration covers all options of the above product.
Is in conformity with:	
Safety: IEC 61010-1:1990 +A1:1992+A2:1995 / EN 61010-1:1994+A2:1995 CAN/CSA-C22.2 No. 1010.1-92	
EMC: CISPR 11:1990/EN 55011:1991 Group 1, Class A IEC 61000-4-2:1995+A1:1998 / EN 61000-4-2:1995, 4 kV CD, 8 kV AD IEC 61000-4-3:1995 / EN 61000-4-3:1995, 3 V/m, 80-1000 MHz IEC 61000-4-4:1995 / EN 61000-4-4:1995, 0.5 kV sig. lines, 1 kV pow. lines IEC 61000-4-5:1995 / EN 61000-4-5:1995, 0.5 kV I-I, 1 kV I-e IEC 61000-4-6:1996 / EN 61000-4-6:1996, 3V 80% AM, power line IEC 61000-4-11:1994 / EN 61000-4-11:1994, 100 %, 20 ms	
Supplementary Information: The product herewith complies with the requirements of the Low Voltage Directive 73/23/EEC and the EMC Directive 89/336/EEC and carries the CE-marking accordingly.	
	
Santa Rosa, CA, USA	30 May 2000
Greg Pfeiffer/Quality Engineering Manager	
For further information, please contact your local Agilent Technologies sales office, agent or distributor.	

Compliance with German Noise Requirements

This is to declare that this instrument is in conformance with the German Regulation on Noise Declaration for Machines (Laermangabe nach der Maschinenlaermverordnung -3.GSGV Deutschland).

Notice for Germany: Noise Declaration

Acoustic Noise Emission	Geraeuschemission
LpA < 70 dB	LpA < 70 dB
Operator position	am Arbeitsplatz
Normal position	normaler Betrieb
per ISO 7779	nach DIN 45635 t.19

Compliance with Canadian EMC Requirements

This ISM device complies with Canadian ICES-001.

Cet appareil ISM est conforme à la norme NMB du Canada.

A

Agilent
sales and service offices, 1-33
Web site, 1-25

B

built-in information system
contents, 4-3
printing, 4-11
refer to for more information, 3-3
temporarily hiding, 4-10
using, 4-2

C

connecting
keyboard, 1-7
mouse, 1-7
connector care, 1-26

D

date, setting, 1-13
depth, 1-4
dimensions, 1-4

E

ergonomics, 2-2

F

fiber optics
connectors, covering, 1-31
functions, 3-3

H

height, 1-4
Help
contents, 4-3
printing, 4-11
refer to for more information, 3-3
temporarily hiding, 4-10
using, 4-2
help language, selecting, 4-12
Help on, 4-7

I

inspection of package contents, 1-4
instrument functions, 3-3
instrument menus, 3-7

K

keyboard
connecting, 1-7
on-screen, 3-10

L

language version, 4-12
line cord
list of available cords, 1-10
line power requirements, 1-9

M

measurement configuration, 4-6
menus, 3-7
Minimize button, 4-10
mouse, connecting, 1-7

N

Noise Declaration, 5-3

O

online Help
contents, 4-3
printing, 4-11
refer to for more information, 3-3
temporarily hiding, 4-10
using, 4-2
on-screen keyboard, 3-10

P

package contents, 1-4
packaging for shipment, 1-31
power
requirements, 1-9
switch, 1-12
printers
Add Printer Wizard, 1-15

Index

driver, 1-15
list of supported, 1-15

R

rack mount
 how to attach, 1-24
 option, 1-6
Restore button, 4-10
returning instrument for service, 1-30

S

safely working, 2-2
Safety Class 1 Product, 1-2
sales and service offices, 1-33
service, returning instrument for, 1-30
shipment, checking package content, 1-4
shipping procedure, 1-31
software keyboard, 3-10
specifications
 complete, 3-3
 related to installation, 1-3

T

time, setting, 1-13
touch screen
 configuration, 1-18
 using, 3-3

W

Web site, Agilent, 1-25
weight, 1-3
width, 1-4